

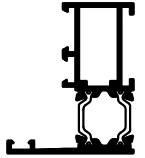

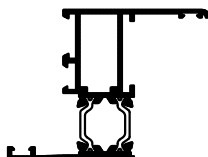

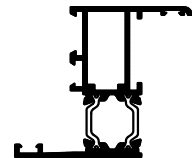

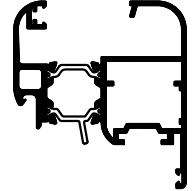

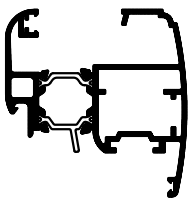
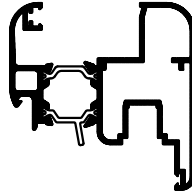
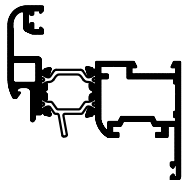
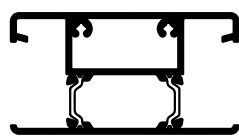
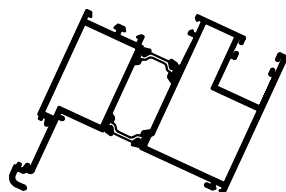
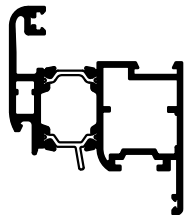
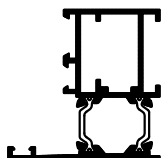
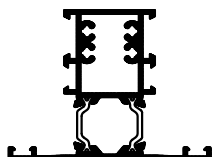
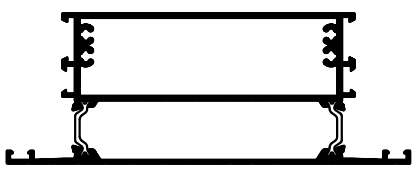
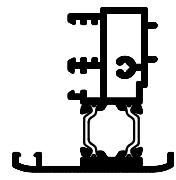
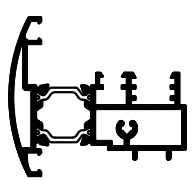
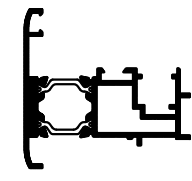
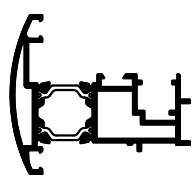
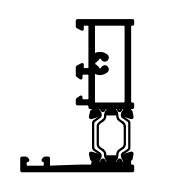
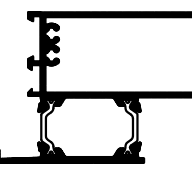
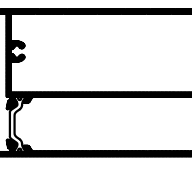
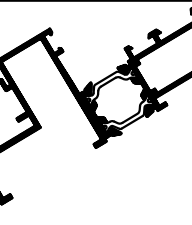
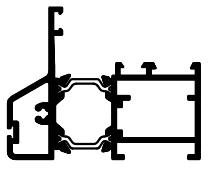
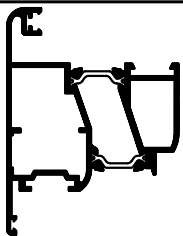
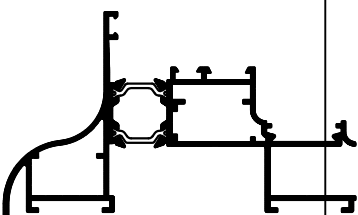
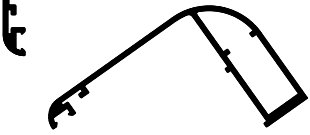
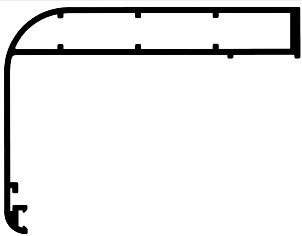
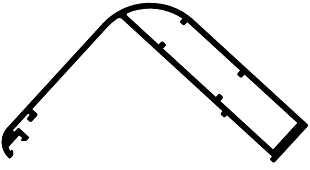

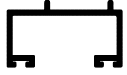





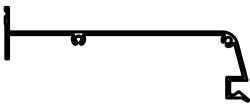

SEZIONE	ARTICOLO	PESO gr/ml	DESCRIZIONE
	TTA701 60102 — 60101	1168 628 — 395	TELAIO AD ELLE
	TTA702 60203 — 60101	1272 747 — 395	TELAIO A ZETA CON BATTUTA DA 30 mm
	TTA703 60304 — 60101	1235 710 — 395	TELAIO A ZETA CON BATTUTA DA 20 mm
	TTA704 60406 — 60405	1677 955 — 600	ANTA CON VETRO AD INFILARE
	TTA704B 60406S — 60405	1776 1020 — 600	ANTA CON VETRO AD INFILARE SCORNICIATA
	TTA704N 60406N — 60405	1843 1087 — 600	ANTA CON VETRO AD INFILARE CON FERRAMENTA A NASTRO
	TTA705 60508 — 60507	1490 747 — 586	ANTA CON FERMAVETRO

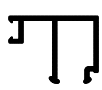
SEZIONE	ARTICOLO	PESO gr/ml	DESCRIZIONE
	TTA706	1794	FASCIA/ZOCCOLO DA 90 mm PER VETRO AD INFILARE
	60610	1139	
	60609	509	
	TTA707	2992	CASSA PER MONOBLOCCO
	60712	1539	
	60711	1307	
	TTA708	1781	ANTA CON FERMAVETRO MAGGIORATA
	60814	906	
	60813	729	
	TTA709	1382	TELAIO AD ELLE MAGGIORATO
	60916	734	
	60915	502	
	TTA711	1676	TI PER TRAVERSI MOBILE E FISSO
	61119	926	
	61118	604	
	TTA712	2896	FASCIONE DA 160 mm PER TRAVERSI MOBILE E FISSO
	61221	1813	
	61220	937	
	TTA713	1553	INVERSIONE DI BATTUTA CENTRALE
	61323	813	
	61322	594	

SEZIONE	ARTICOLO	PESO gr/ml	DESCRIZIONE
	TTA713B	1609	INVERSIONE DI BATTUTA CENTRALE ARROTONDATO
	61323	813	
	61322B	650	
	TTA713N	1442	INVERSIONE DI BATTUTA FERRAMENTA NASTRO
	61323N	702	
	61322	594	
	TTA713BN	1498	INVERSIONE DI BATTUTA F. NASTRO ARROTONDATO
	61323	702	
	61322B	650	
	TTA714	1045	ELLE A PAVIMENTO
	61425	567	
	61424	332	
	TTA715	1921	ZOCCOLO RIPORTATO MOBILE E FISSO
	61527	1268	
	61526	507	
	TTA717	2884	FASCIA VETRO INFILATO DA 160
	61731	1902	
	61730	836	
	TTA718	2333	SPALLA APERTA MONOBLOCCO
	61833	1107	
	61832	1080	

SEZIONE	ARTICOLO	PESO gr/ml	DESCRIZIONE
	TTA719 61934 60916	1651 771 734	CIELINO MONOBLOCCO
	TTA720 62036 62035	1867 1107 614	ANTA APERTURA ESTERNA
	TTA721 62237 62238	2971 1506 1320	TELAIO SPECIALE X CAPANNONI
	R4557	2971	IMBOTTE DA
	R4558	2971	TELAIO SPECIALE X CAPANNONI
	R4559	2971	TELAIO SPECIALE X CAPANNONI
	M0785	100	COPRIVITI PER MONOBLOCCO

SEZIONE	ARTICOLO	PESO gr/ml	DESCRIZIONE	
	TTA 610	464	SOTTO ZOCCOLO	
	R 3805	110	TAPPO COPRIVITI X MONOBLOCCO	
	R 3806	132	ASTINA COMANDO LEVE	
	M 0570	180	ASTINA PER CREMONESE	
	RA6805	856	CIELINO PER MONOBLOCCO	
	MF3362	1150	TAPPO CASSONETTO	
	MF3363	1379	LATERALE CASSONETTO	

	R 3823	230	FERMAVETRO DA 10 mm
	R 3824	269	FERMAVETRO DA 18.5 mm
	R 3827	310	FERMAVETRO DA 35 mm
	R 3663	245	FERMAVETRO ARROTONDATO DA 14 mm
	R 3668	275	FERMAVETRO ARROTONDATO DA 18,5mm
	R 3664	272	FERMAVETRO ARROTONDATO DA 25 mm
	R 3810	322	FERMAVETRO ARROTONDATO DA 32 mm
	R 3810	322	FERMAVETRO A MOLLA DA 14 mm
	R 3810	322	FERMAVETRO A MOLLA DA 18.5 mm
	R 3810	322	FERMAVETRO A MOLLA DA 21 mm

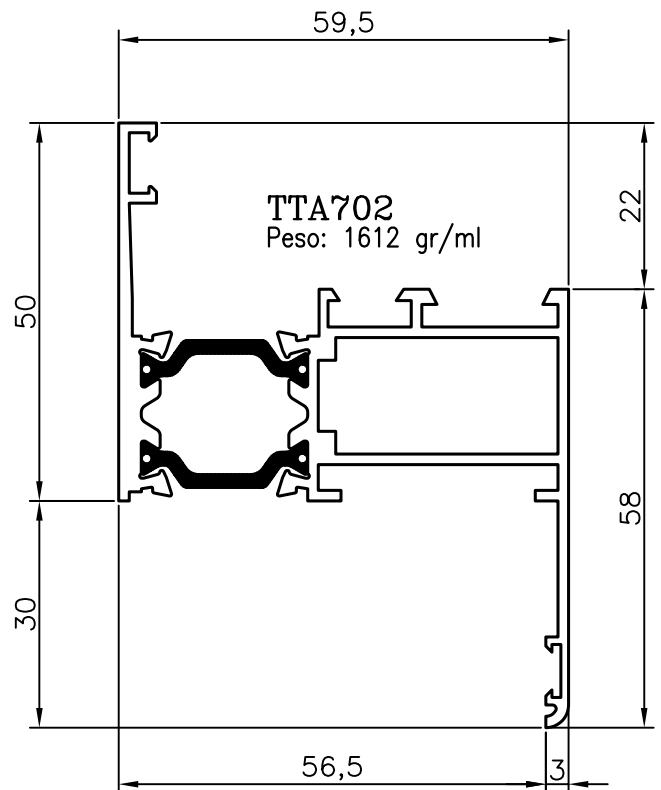
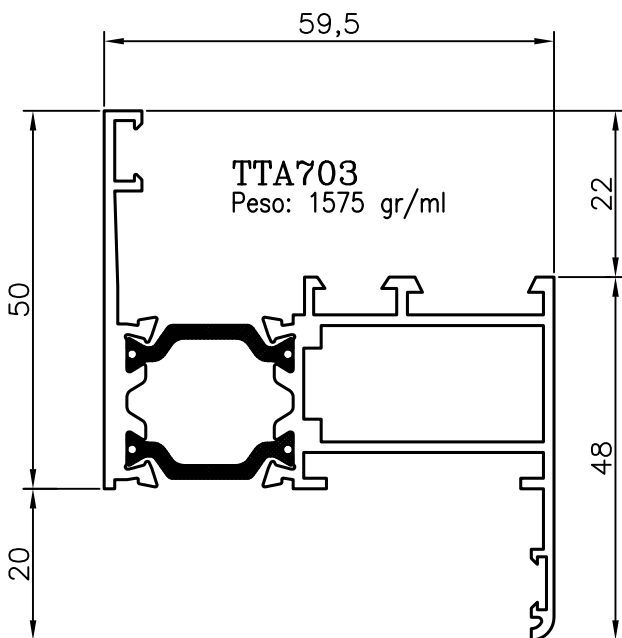
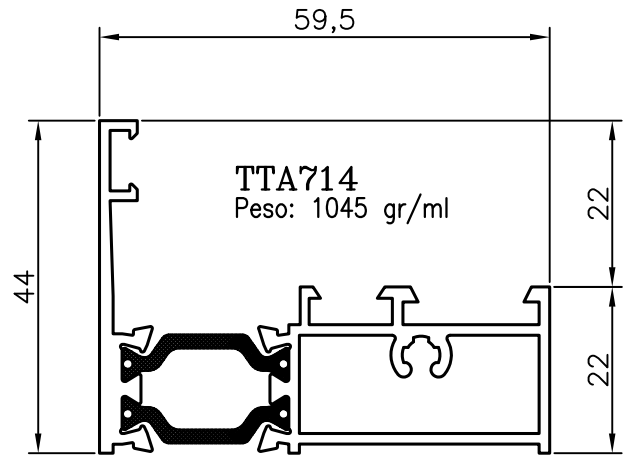
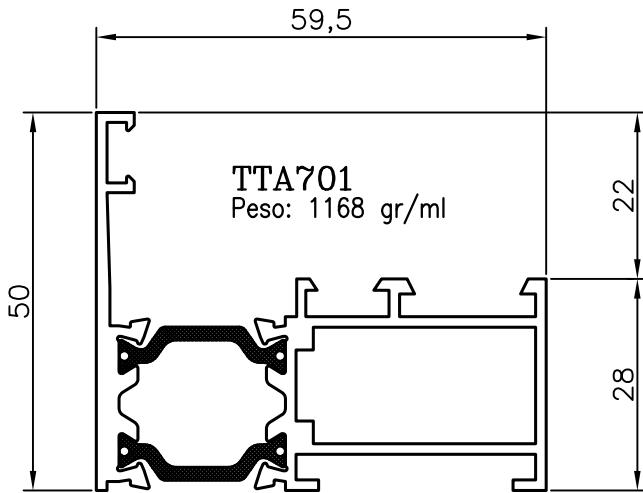

TTA700

Taglio Termico a battente

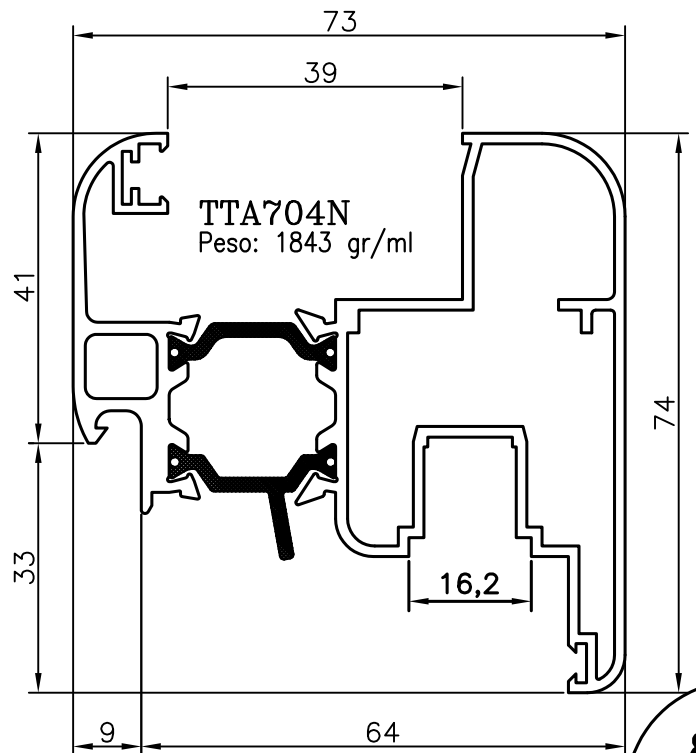
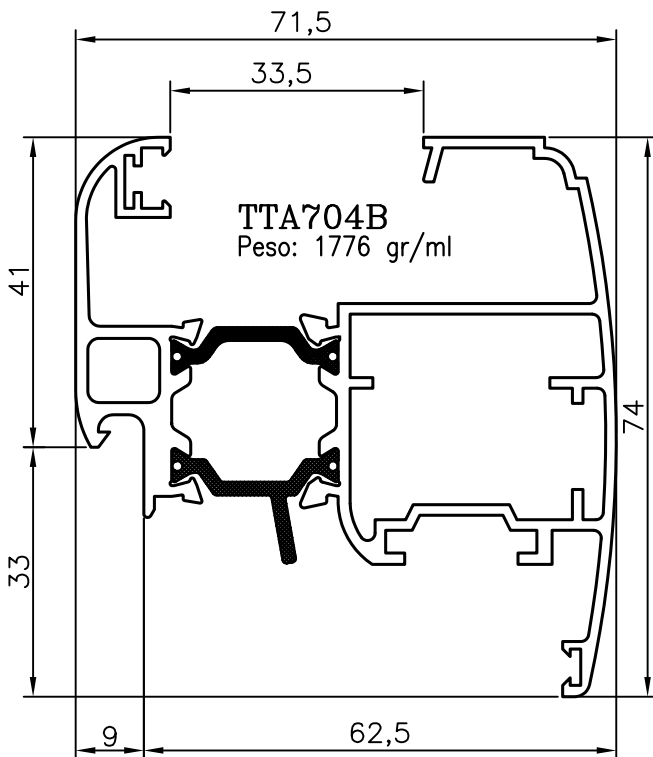
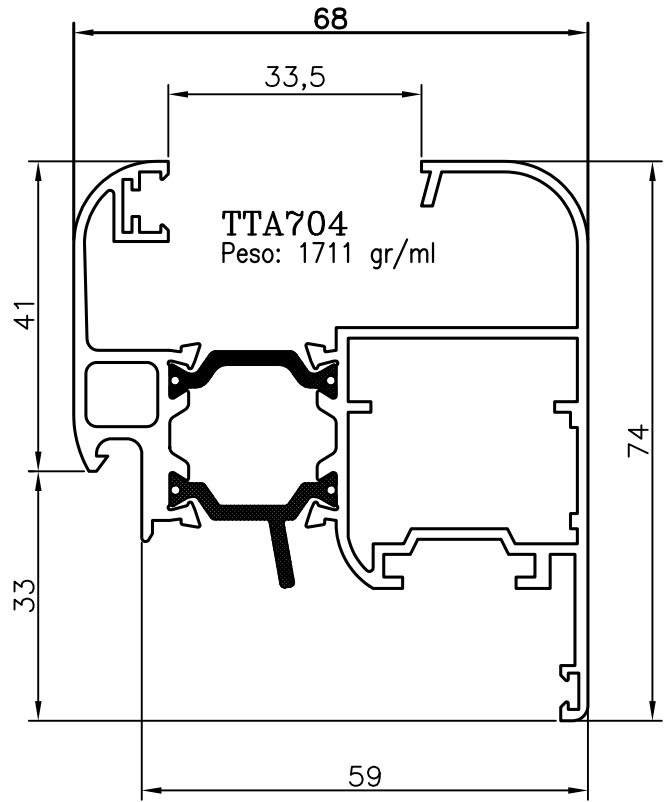
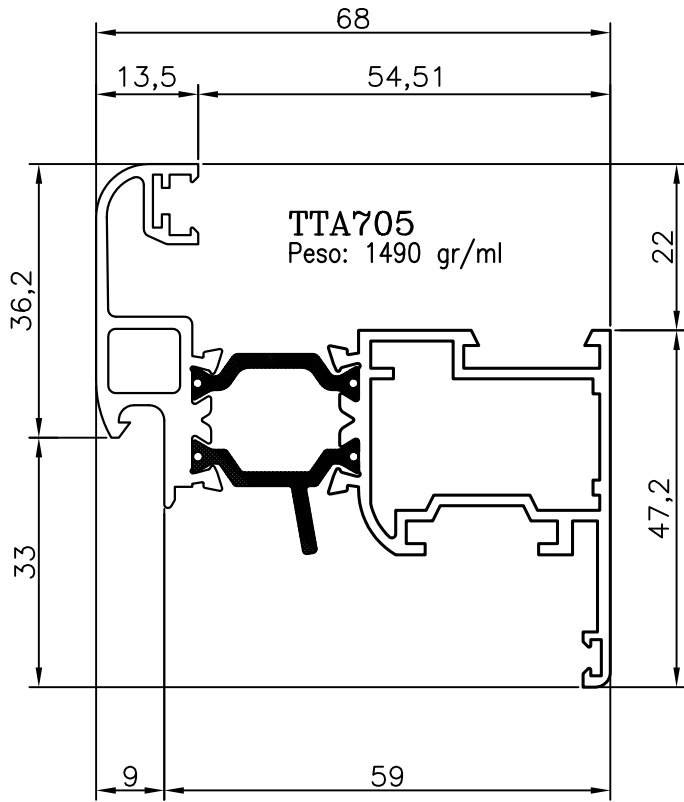

TTA700

Taglio Termico a battente

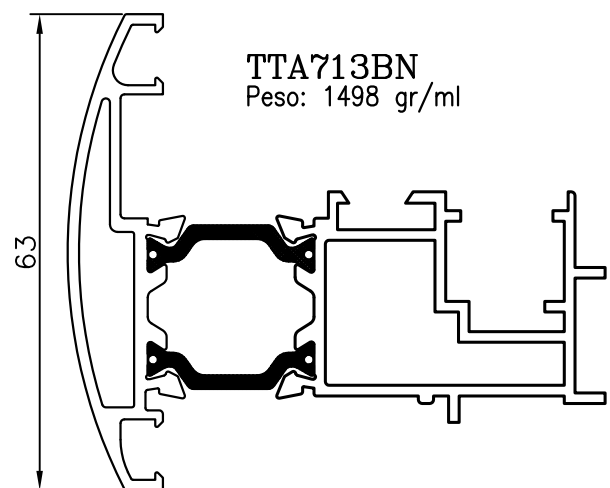
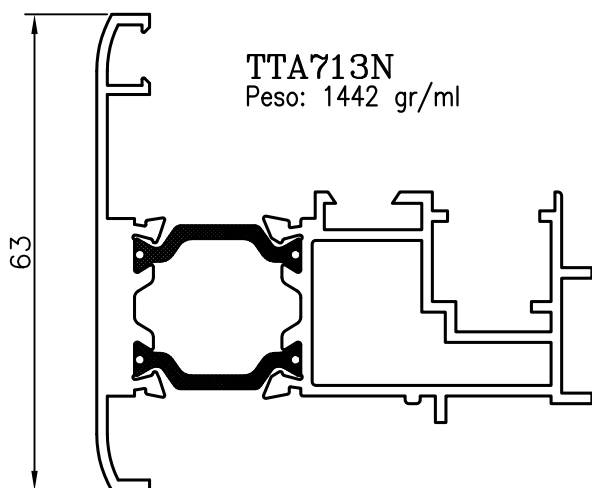
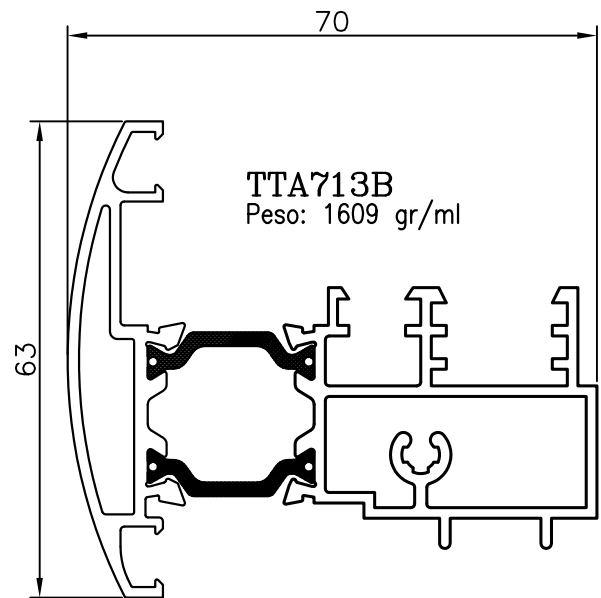
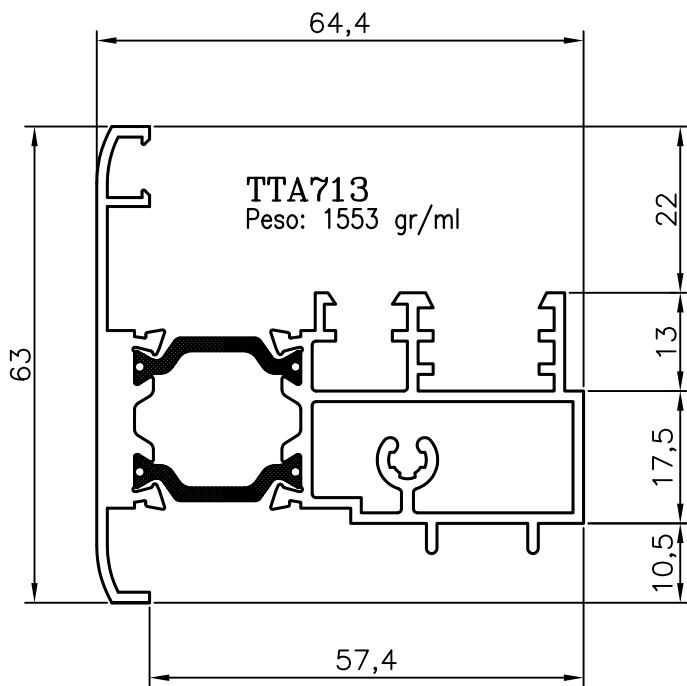

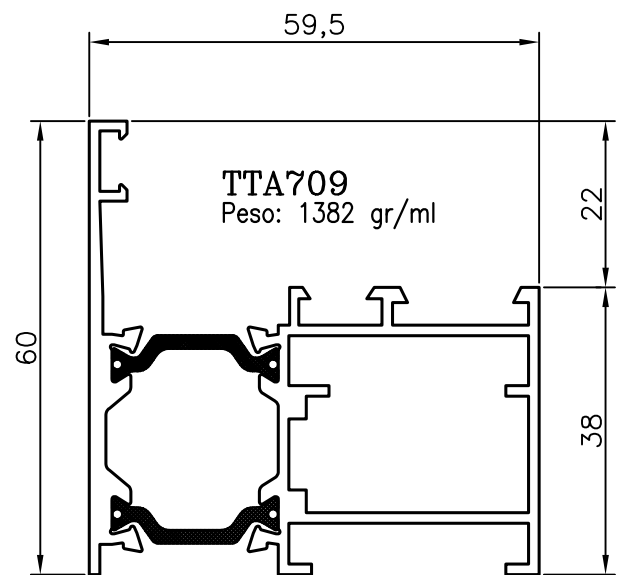
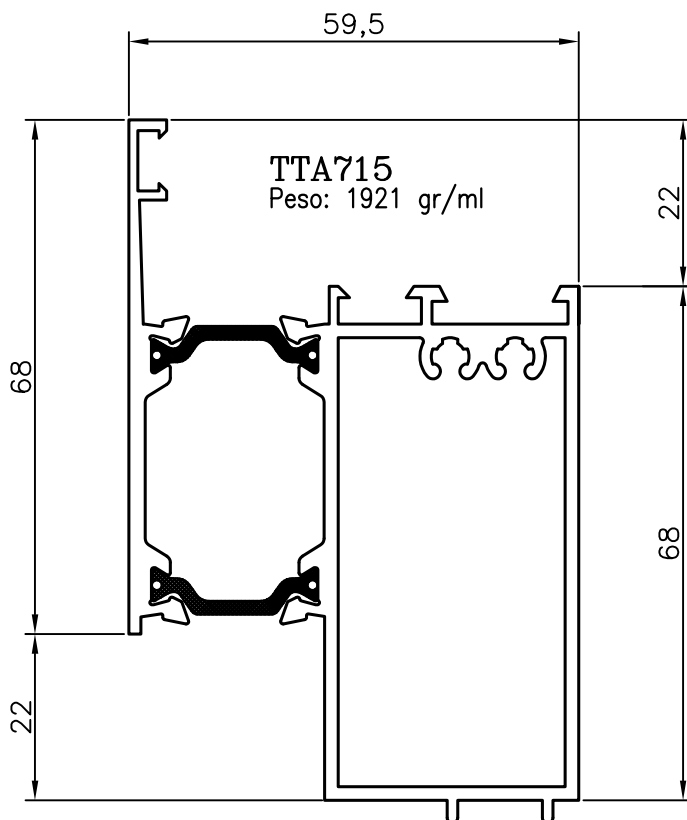
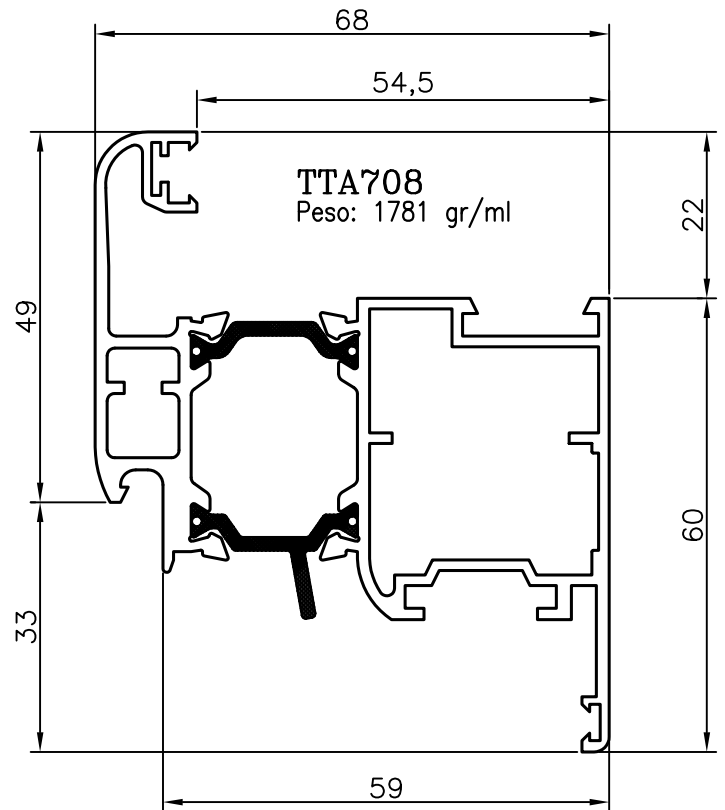
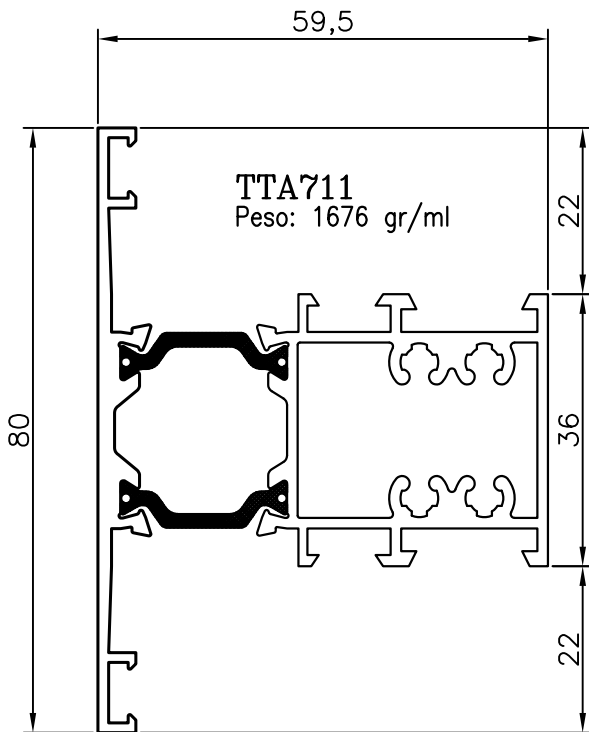

TTA700

Taglio Termico a battente

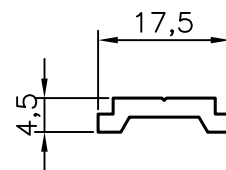
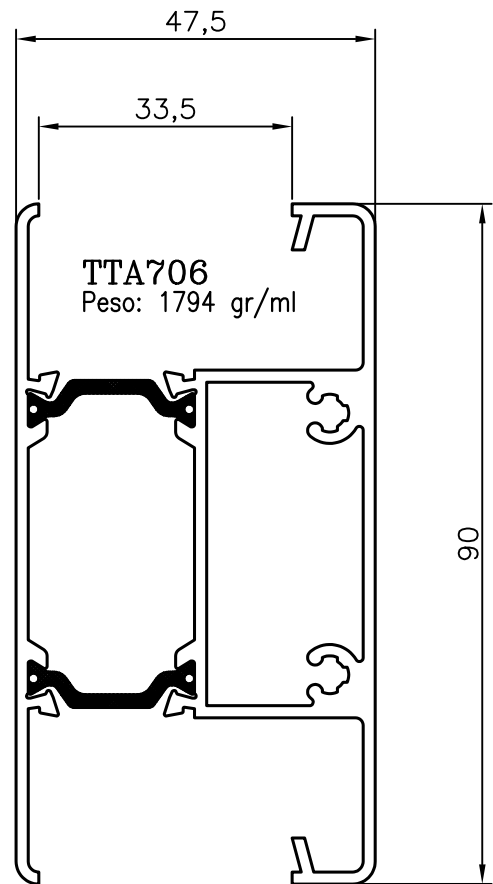
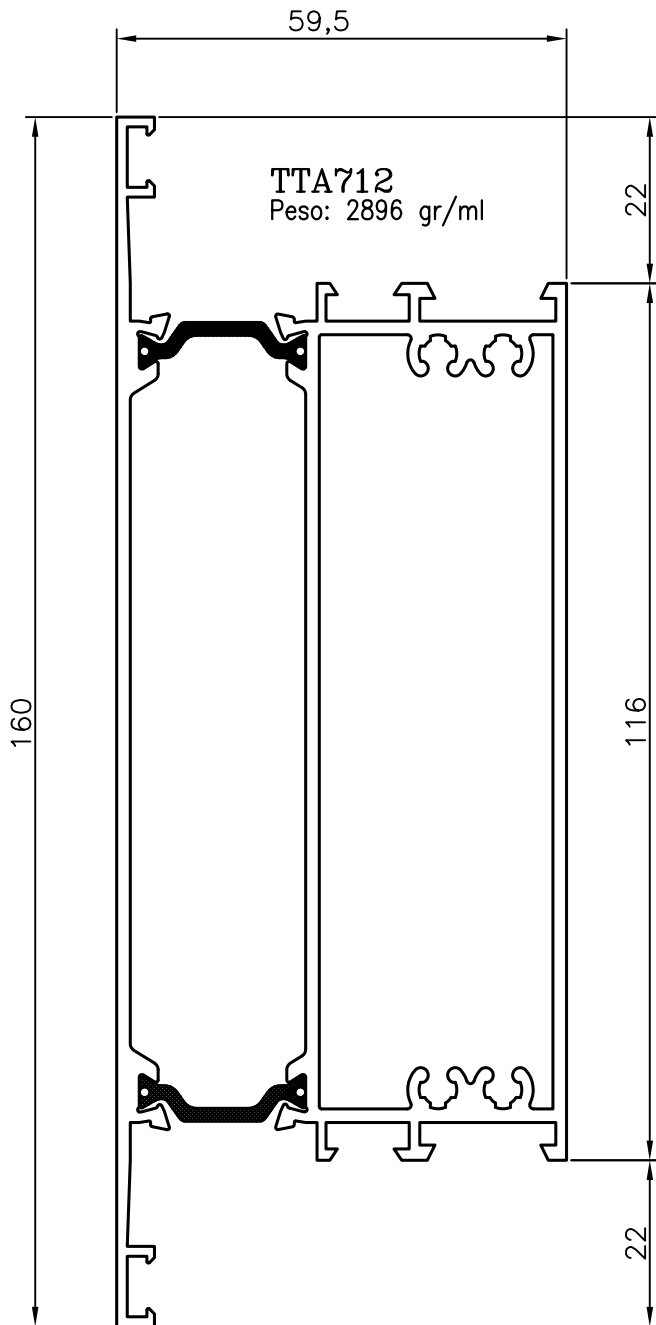

R3806
Peso: 132 gr/ml

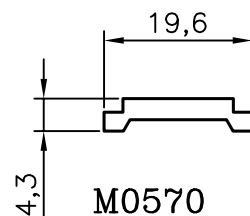
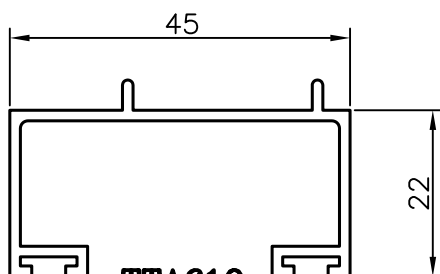

TTA700

Taglio Termico a battente

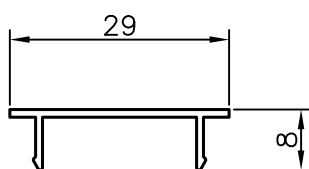
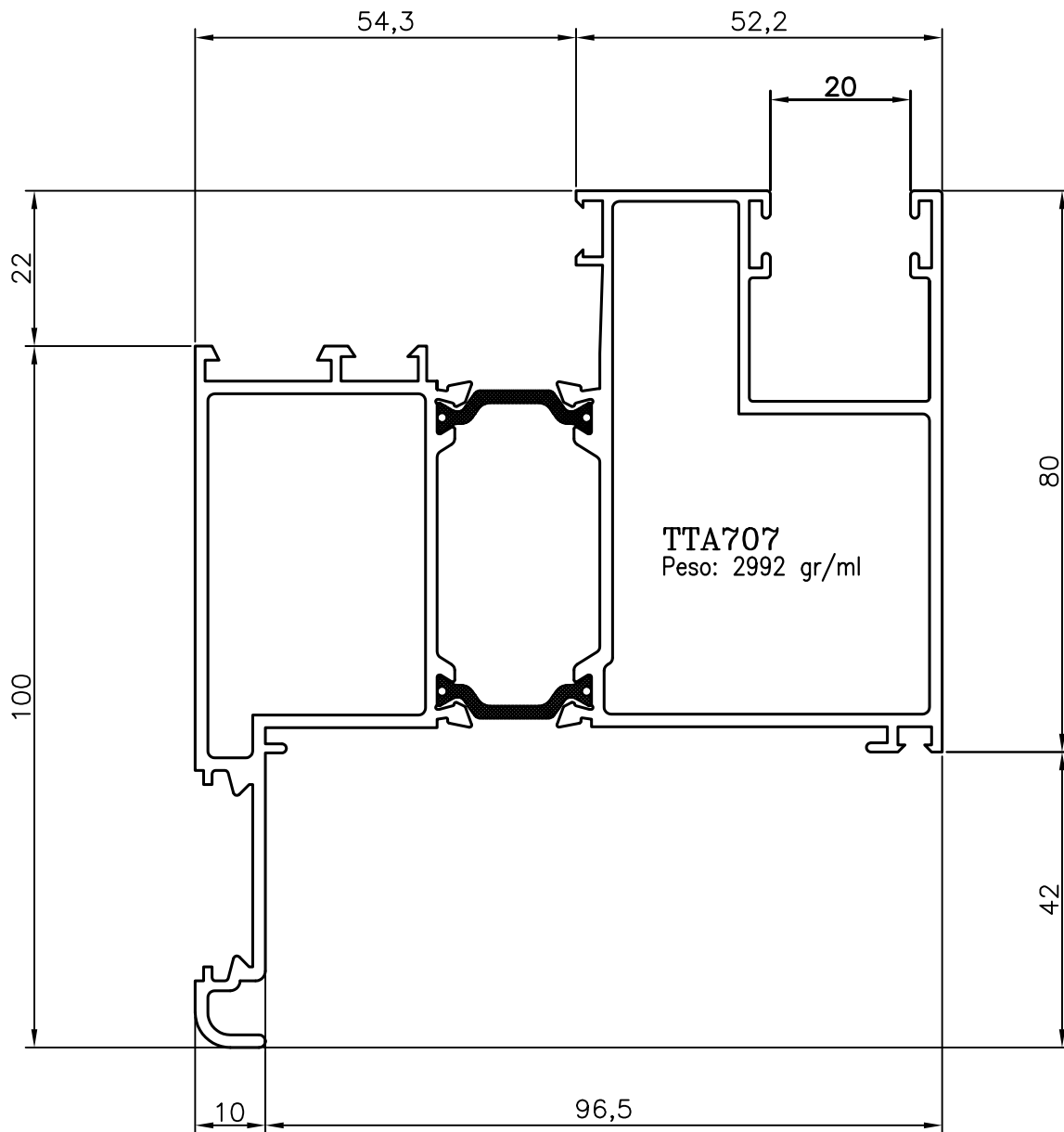

R3805
Peso: 110 gr/ml

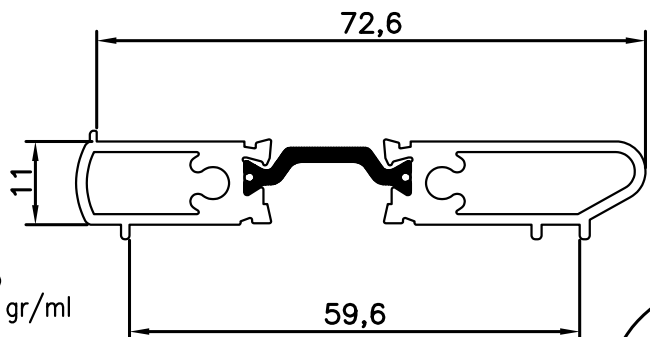

RA6805
Peso: 856 gr/ml

TTA700

Taglio Termico a battente

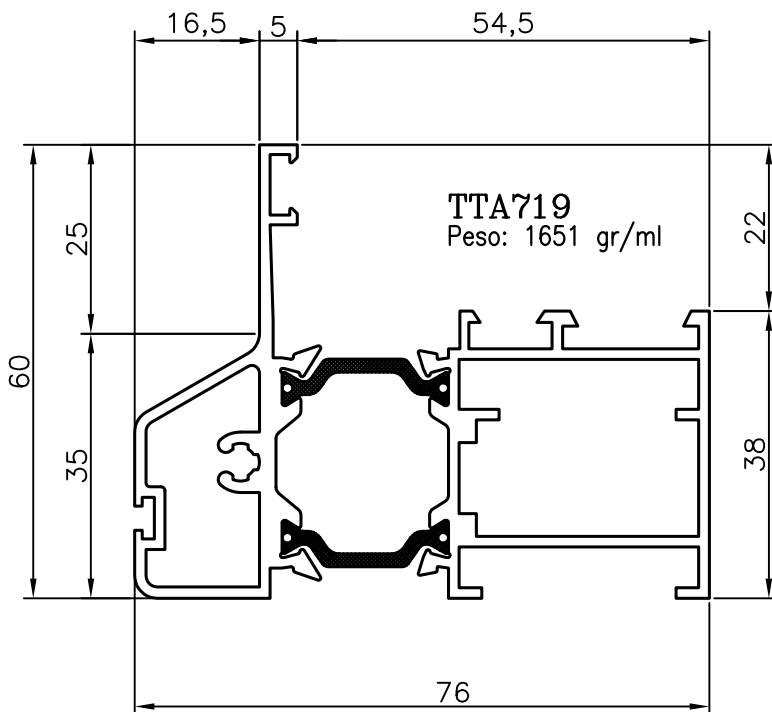
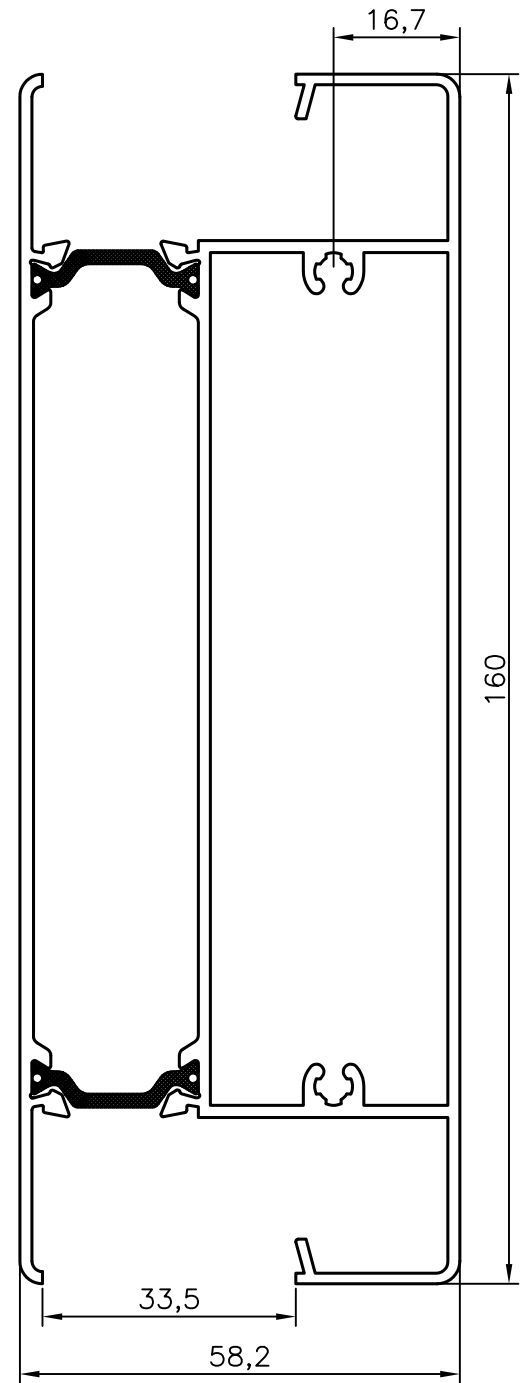
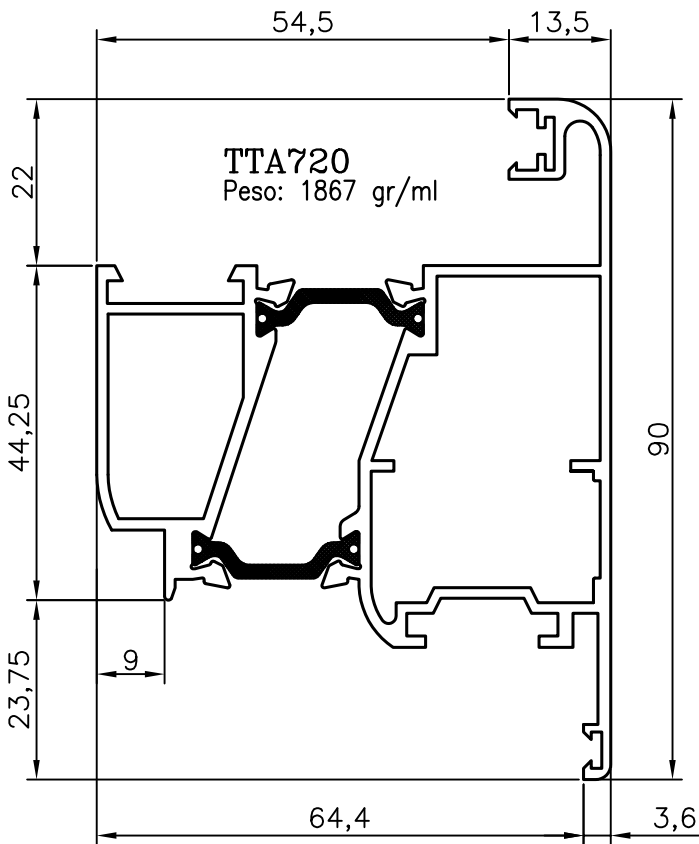

TTA717
Peso: 2884 gr/ml

TTA700

Taglio Termico a battente

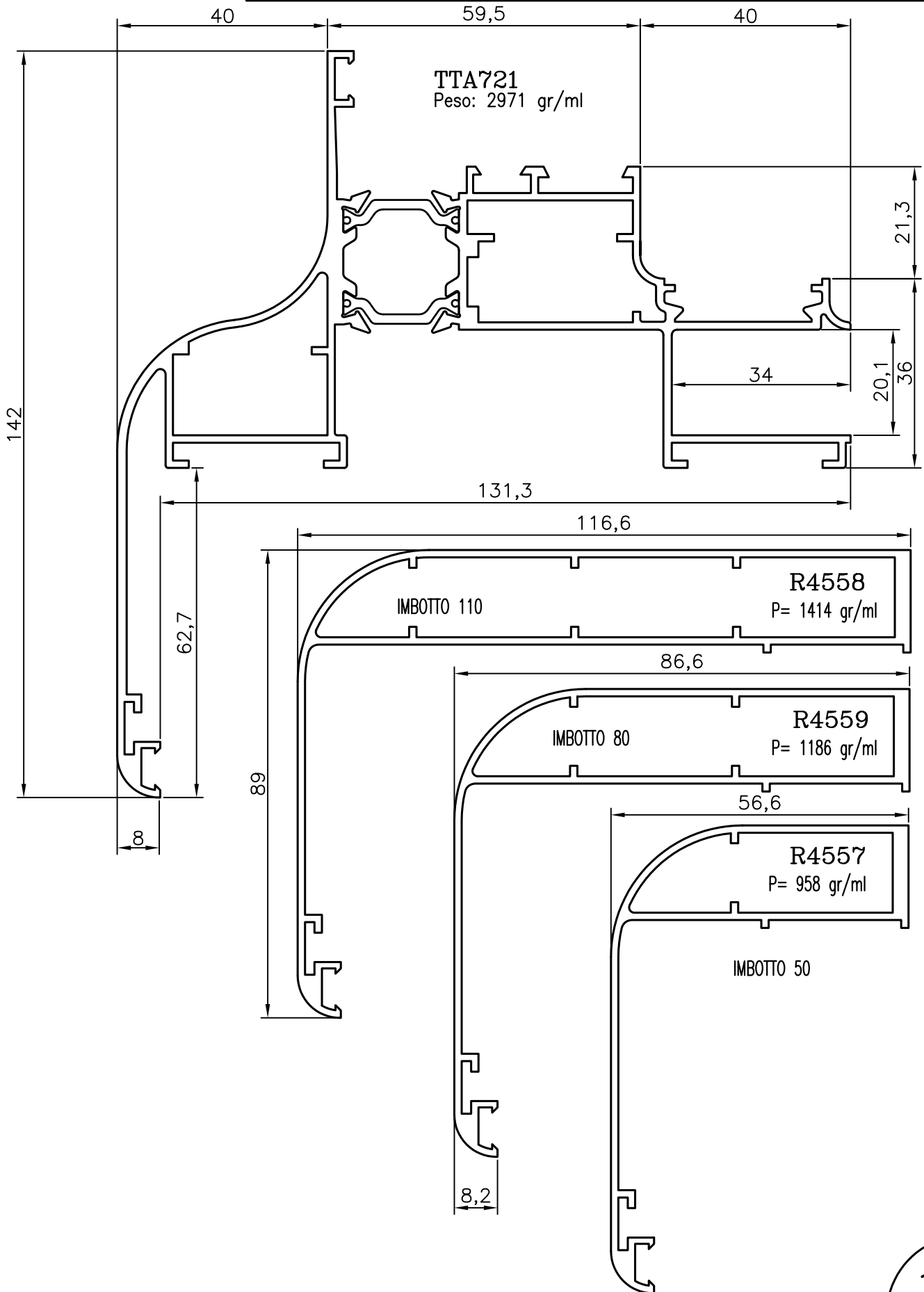

TTA700

Taglio Termico a battente

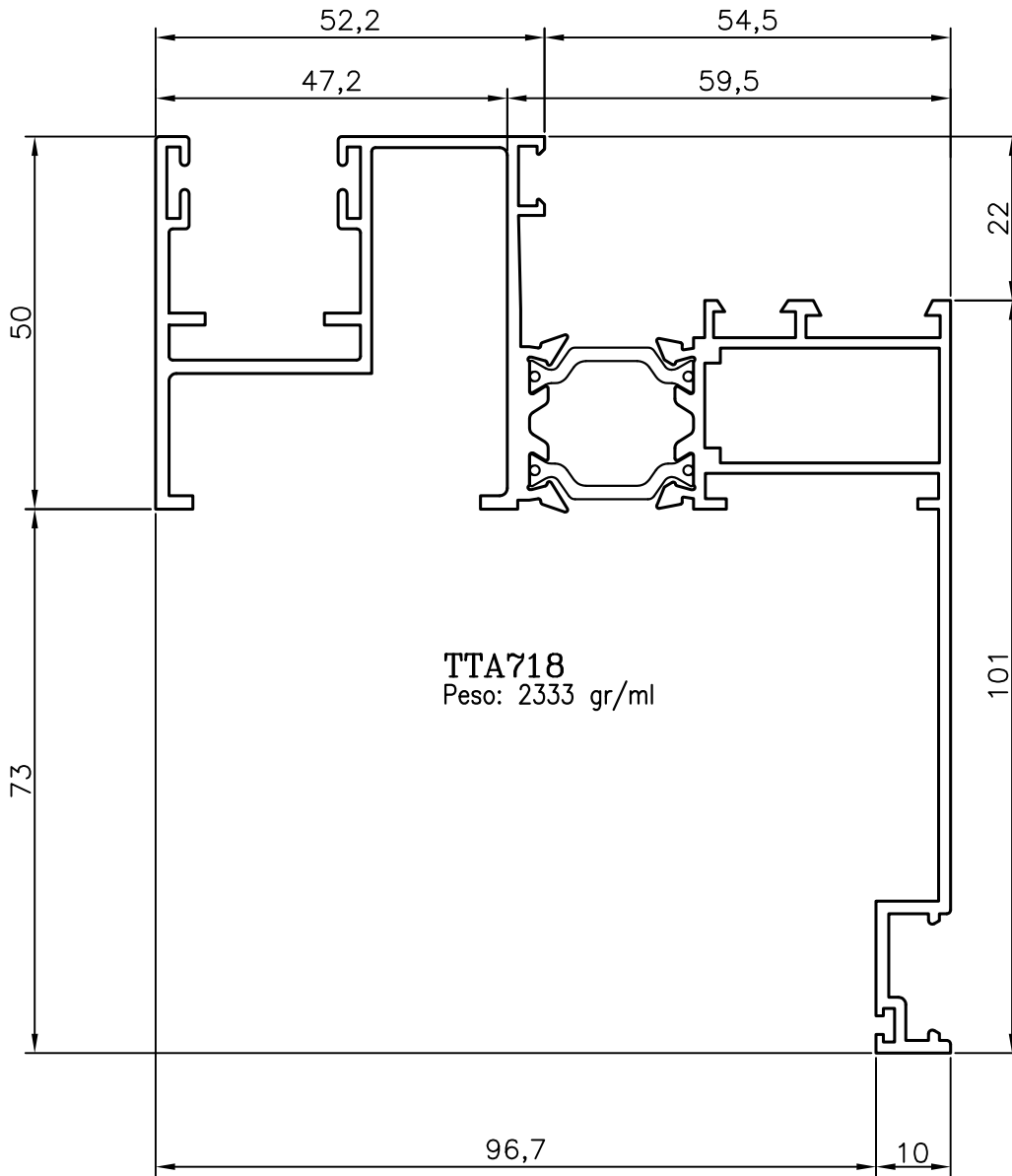

TTA718
Peso: 2333 gr/ml

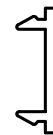

M0785
Peso: 100 gr/ml

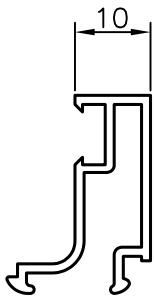

R 3823
230 gr/ml

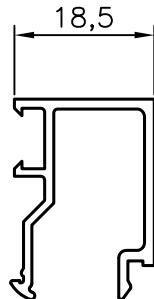

R 3824
269 gr/ml

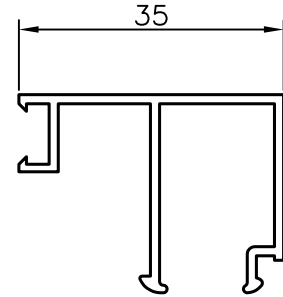

R 3827
310 gr/ml

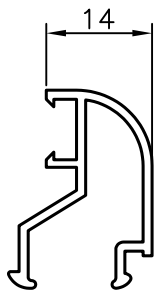

R 3663
245 gr/ml

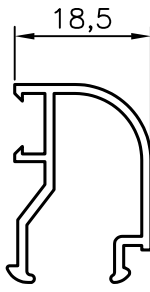

R 3668
275 gr/ml

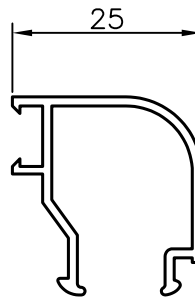

R 3664
272 gr/ml

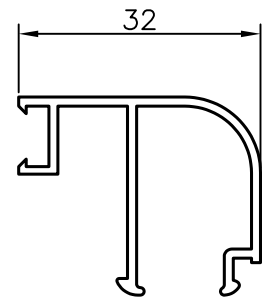

R 3810
322 gr/ml

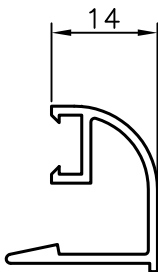

R 4546
215 gr/ml

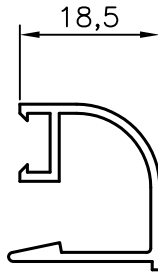

R 4547
230 gr/ml

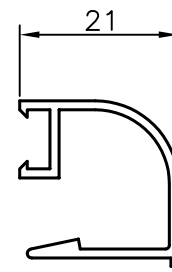

R 4548
238 gr/ml